

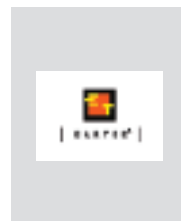

**PCx  
Digital  
Wireless  
Communication  
System**



**EARTEC CO.**  
145 Dean Knauss Drive  
Narragansett, RI 02882  
Tel: 1-800-399-5994  
In RI: 401-782-4966  
Fax: 401-789-7300

## PCx Digital Wireless Features

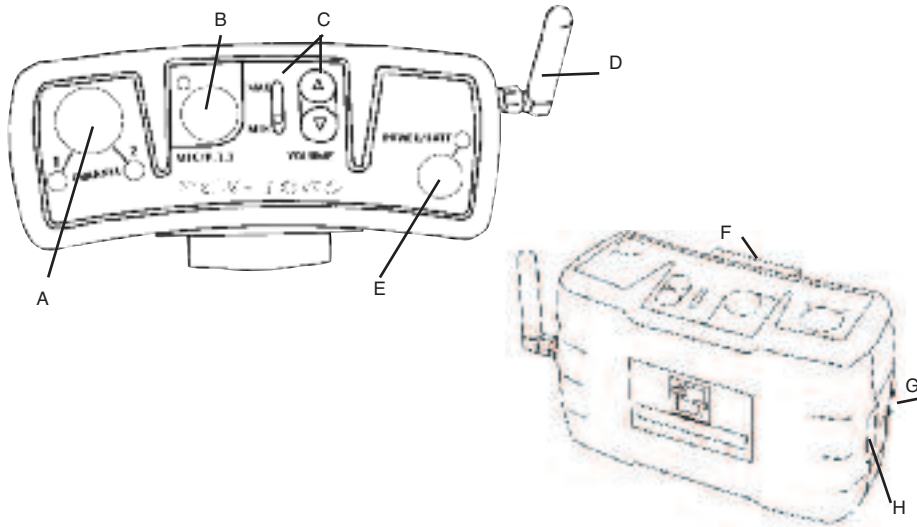

A	<b>Channel Selector</b> - Red indicates channel 1 or channel 2.
B	<b>PTT Option</b> - On/Off Mic PTT Switch is an optional feature that is programmed at the time of purchase.
C	<b>Volume Control</b> - Green LED indicator.
D	<b>Antenna</b>
E	<b>Power Indicator</b> - Glows green when radio is turned on and battery is charged.
F	<b>Belt Clip</b>
G	<b>Battery Compartment</b>
H	<b>Headset jack</b>

**NOTE:** To communicate properly, all radios in the group must be components of a matched set which are identified by the same ID Code number, located at the bottom of the radio.



1

www.eartec.com

## PCx Digital Wireless Instructions

### Charging the Radios

The batteries that provide power to your system do not need to be “drained”. Simply follow the procedure below within 48 hours before each use:

1. Insert batteries into rapid charger firmly.
2. Charge batteries for 4 to 7 hours.
3. Red LED indicates that the batteries are charging.
4. Green LED indicates that the batteries are fully charged.
5. For optimum battery life, remove battery from charger within 12 hours after light turns green.

**NOTE:** When reinserting battery into PCx radio, battery must be firmly seated behind housing ridge. Hand-tighten thumbscrew to close. Important: do not over-tighten thumbscrew.

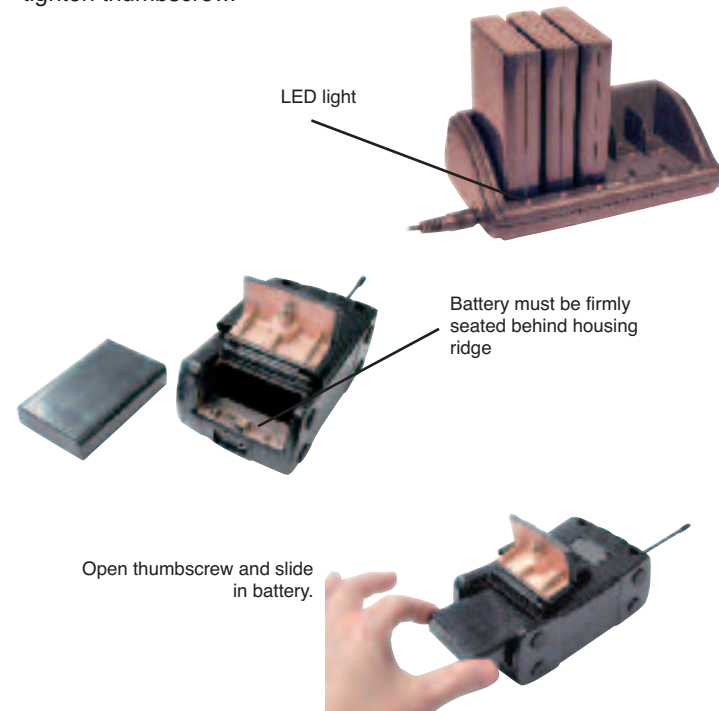

**NOTE:** Batteries should be properly conditioned while not in use for long periods of time - please charge every six weeks.

www.eartec.com

2



# PCx Digital Wireless System Set-up

# Specifications

Eartec customer service: 1-800-399-5994

## Identify Your Radios

1. Each PCx series consists of MASTER and REMOTE radios.
2. MASTER radios are the Master Transmitters and MUST be powered on first.
3. REMOTE radios MUST be powered on last.

## Setup MASTER Radios - PCx-1000

1. Charge radios as indicated on page two.
2. Begin with all radios OFF.
3. Plug headsets into headset jack.
4. Turn ON Master radio. Hold power button until LED lights appear.
5. Wait 15 seconds before turning on Remote radios.
6. Turn ON Remote radios one at a time.
7. Clip radios to the right hip.
8. Select channel and volume.

## IMPORTANT

All PCx wireless are self-tuning. If the signal is unclear, simply restart the MASTER radio. It will automatically locate a free channel.

**IMPORTANT NOTE:** Eartec headsets include a special noise cancelling microphone that provides digital voice translation. For optimum performance adjust microphone boom so the element is directly in front of, and approximately 1" - 2" from the user's mouth, making sure the word TALK and the arrow are situated in front of mouth.



<b>FCC Model#</b>	B4HPCX1000 No license required
<b>Dimensions Weight</b>	5 x 2 x 3 inches 11 oz*
<b>Modulation If Bandwidth</b>	Spread spectrum 902-928 MHz
<b>Range Transmit Power</b>	Up to 1/4 mile 250 mA
<b>Antenna Temp Range</b>	Center fed dipole -20 degrees C to +65 degrees C
<b>Battery Battery Life</b>	NiMh 2200mA Eight hours
<b>Mic Type Mic Sensitivity</b>	Noise cancelling electret -43dB
<b>FQ Response Mic Impedance</b>	50Hz - 15kHz 3k ohm
<b>S/N Ratio</b>	64dB @94dB SPL

\*without battery

**NOTE:** Do NOT service this equipment. If you require service, contact Eartec customer service at 1-800-399-5994.



## Warranty

Eartec communication systems are warranted from malfunction due to manufacturing defects by the original purchaser for the following periods after date of purchase:

### Transceivers

PCx	1 year
Digicom	1 year
MC-1000	1 year
TD900	6 months
Simultalk 24G	6 months

### Headsets

Heavy Duty	1 year
Midweight	6 months
Lightweight	30 days

**Rechargeable batteries** 60 days

## What is Covered

This warranty covers defects in materials and workmanship in all Eartec products excluding:

- (a) Damage from misuse, abuse, or general wear and tear.
- (b) Repairs or product modifications by anyone not authorized by Eartec Co.

## Warranty Service

If you require warranty service for your product within the warranty period ship your product pre-paid only to Eartec. The end user is responsible for the initial shipping charges to our facility. Eartec will pay the return ground shipping charges if the product is covered under the warranty.

## General Service

All repair work due to general wear and tear will be performed for the cost of replacement parts, radio retuning and return shipping from the Eartec factory.

**Service  
Eartec Co.  
145 Dean Knauss Drive  
Narragansett, RI 02882**

**COD** or **Collect** deliveries will not be accepted.

A letter explaining any problems and work to be performed must accompany each repair shipment with:

**Name  
Business  
Complete Address  
Telephone Number  
Email Address**

## Returns

Eartec products may be returned for credit or refund only if received in the original packing and in "As New" condition within 30 days of date of purchase.

